



PHOENIX

PRIZE

FLEXIBLE COIL SINK MIXER

PRODUCT CODE: I0273100C
 FINISH: CHROME
 WELS: 5 STAR - 6.0 LT/MIN

INFORMATION:

MATERIAL: BRASS
 TEMPERATURE RATING: MIN 1° - MAX 75°
 PRESSURE RATING: MIN 150 kPa - MAX 500 kPa

CONSUMER UNIT:

SIZE: L 610MM x W 290MM x H 75MM
 GROSS WEIGHT: 2.7 KG
 BARCODE EAN-13: 9 320594 024 284

SPECIFICATIONS



AVAILABLE IN:



CHROME



BRUSHED NICKEL

FOR MORE INFORMATION VISIT
www.phoenixtapware.com.au

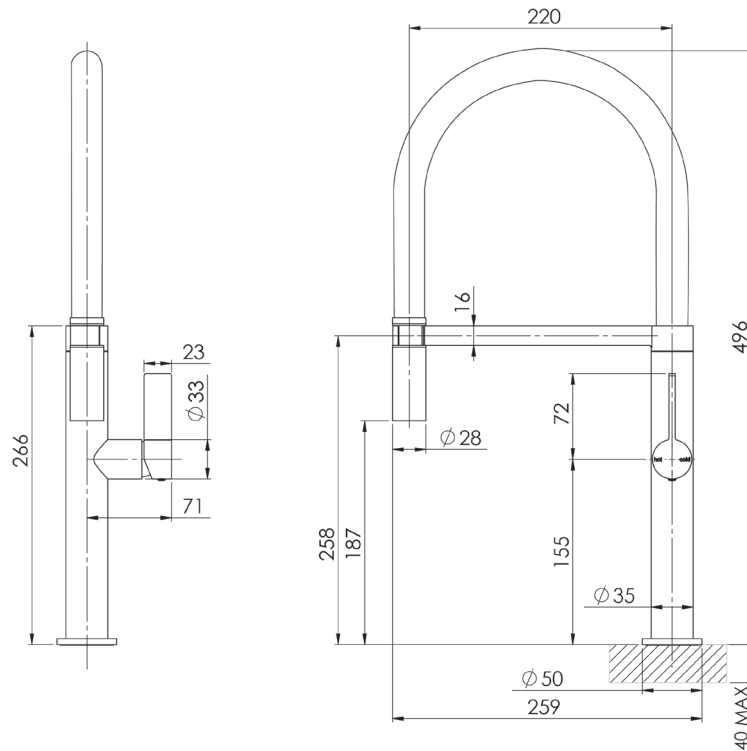

PLEASE [CLICK HERE](#) TO VIEW FULL WARRANTY

While we aim to ensure the specifications shown are correct at time of printing, Phoenix Tapware reserves the right to make modifications without prior notice. Always use the physical product measurements for mark-ups and roughing-in as the line drawing shown may differ from the actual product over time. All measurements are shown in millimetres.

www.phoenixtapware.com.au
03 9780 4200



PHOENIX

SPECIFICATIONS

PRIZE

FLEXIBLE COIL SINK MIXER

PRODUCT CODE: 10273100C
 FINISH: CHROME
 WELS: 5 STAR - 6.0 LT/MIN

PARTS LIST

1. MIXER BODY
2. CARTRIDGE SEAT
3. BRASS DISC
4. MIXER SHAFT
5. PLASTIC BEARING
6. 25MM CARTRIDGE
7. LOCKNUT
8. MIXER DOME
9. MIXER HANDLE
10. GRUB SCREW M5X5MM
11. SCREW CAP
12. HAND PIECE HOLDER
13. HOSE AND ADAPTOR
14. PLASTIC BEARING
15. SPRING RETAINER
16. HAND PIECE
17. HAND PIECE PLASTIC BEARING
18. AERATOR
19. HAND PIECE SPRING RETAINER
20. SPRING 520MM
21. LOCKNUT GASKET
22. MIXER TAIL
23. PLASTIC MIXER LOCKNUT
24. MOUNTING DISC
25. O-RING 41X2.5MM
26. MIXER DRESS PLATE
27. SWIVEL SPACER
28. FLEXIBLE HOSE 450MM COLD
29. FLEXIBLE HOSE 450MM HOT

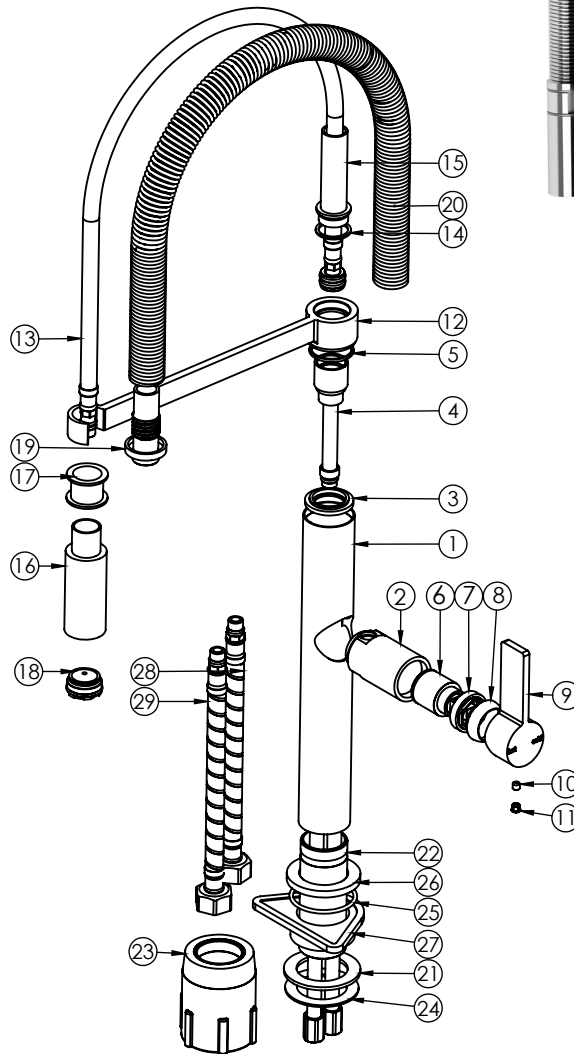

MAINTENANCE AND CARE:

- Chrome plated surfaces should be cleaned with mild liquid detergent or soap and water;
- Do not use cream cleaners or citrus based cleaning products, as they are abrasive.
- Use of unsuitable cleaning agents may damage the surface. Any damage caused in this way will not be covered by warranty.

PACKAGING INCLUDES

- 1 x Flexible coil sink mixer
- 1 x 450mm braided flexible cold hose
- 1 x 450mm braided flexible hot hose
- 1 x Installation kit
- 1 x Installation instructions
- 1 x Warranty card

PLEASE [CLICK HERE](#) TO VIEW FULL WARRANTY

While we aim to ensure the specifications shown are correct at time of printing, Phoenix Tapware reserves the right to make modifications without prior notice. Always use the physical product measurements for mark-ups and roughing-in as the line drawing shown may differ from the actual product over time. All measurements are shown in millimetres.

www.phoenixtapware.com.au
03 9780 4200