



# PHOENIX

## SPECIFICATIONS

IVY

### BASIN SET

PRODUCT CODE:	600 CHR
FINISH:	CHROME
WELS:	5 STAR - 5 LT/MIN
<b>INFORMATION:</b>	
MATERIAL:	BRASS
TEMPERATURE RATING:	MIN 1° - MAX 75°
PRESSURE RATING:	MIN 150 kPa - MAX 500 kPa



AVAILABLE IN:



CHROME

FOR MORE INFORMATION VISIT  
[www.phoenixtapware.com.au](http://www.phoenixtapware.com.au)

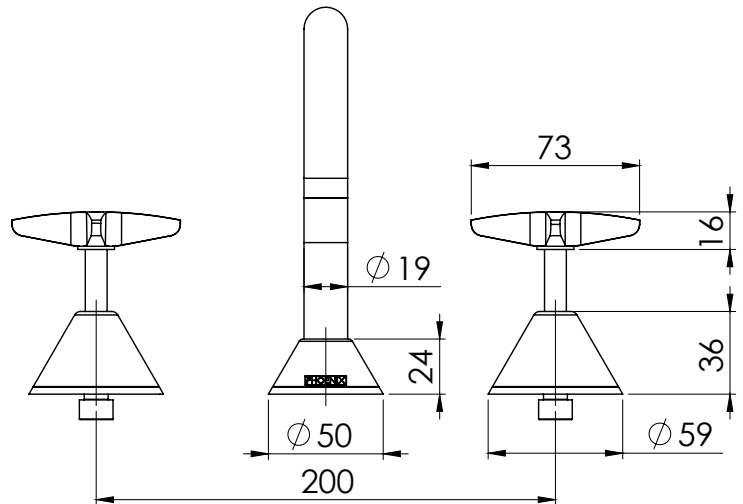
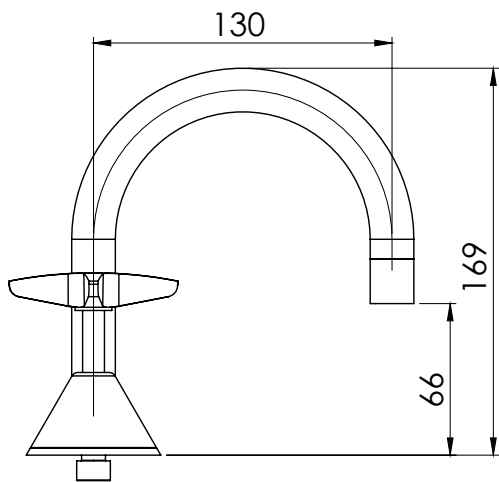

PLEASE [CLICK HERE](#) TO VIEW FULL WARRANTY

While we aim to ensure the specifications shown are correct at time of printing, Phoenix Tapware reserves the right to make modifications without prior notice. Always use the physical product measurements for mark-ups and roughing-in as the line drawing shown may differ from the actual product over time. All measurements are shown in millimetres.

Ivy is a Registered Trademark of Phoenix Industries Pty. Ltd.

V230816

[www.phoenixtapware.com.au](http://www.phoenixtapware.com.au)  
03 9780 4200



# PHOENIX

## SPECIFICATIONS

### IVY

## BASIN SET

PRODUCT CODE:

600 CHR

FINISH:

CHROME

WELS:

5 STAR - 5 LT/MIN



### PARTS LIST

1. BASIN TAP ASSY
2. BASIN T PIECE
3. LOCKNUT
4. SPOUT
5. NOZZLE RETAINER
6. AERATOR
7. GASKET
8. NYLON WASHER
9. M18 OUTLET TAIL
10. O-RING 16X2.0MM
11. TAP BODY ASSY
12. SPLINE 89 MM
13. TAP FLANGE
14. NUT
15. ANTI VANDAL HANDLE KIT
16. HANDLE
17. WASHER
18. CONNECTOR
19. LOCKNUT

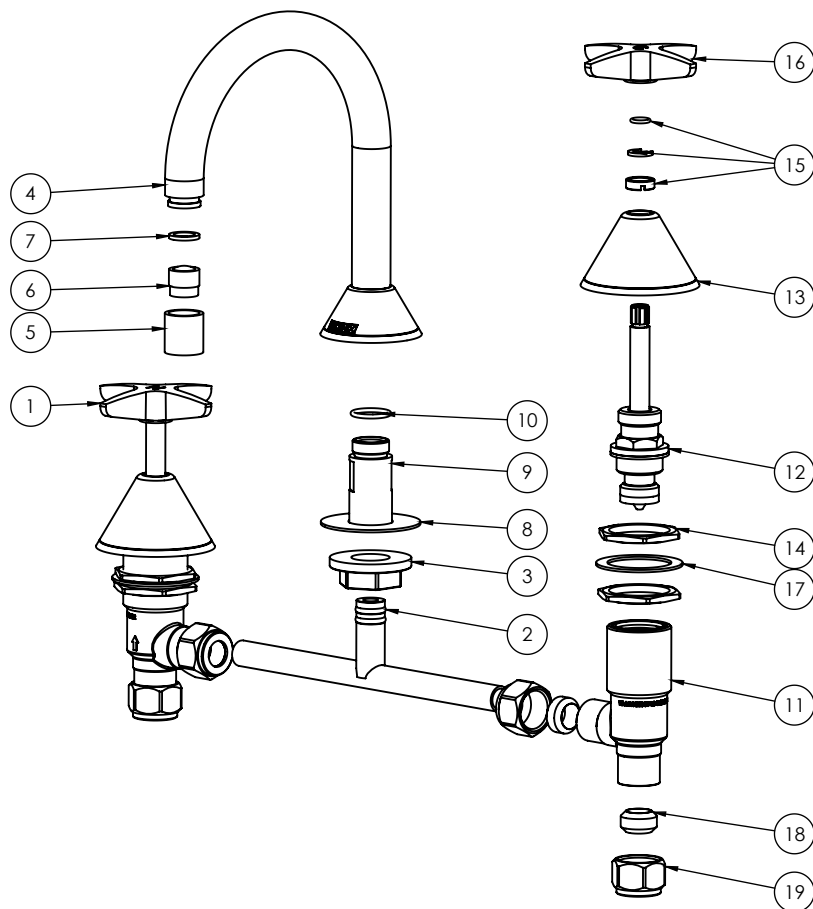

### MAINTENANCE AND CARE:

- All surfaces should be cleaned with mild liquid detergent or soap and water.
- Do not use cream cleaners or citrus based cleaning products, as they are abrasive.
- Use of unsuitable cleaning agents may damage the surface. Any damage caused in this way will not be covered by warranty.

### PACKAGING INCLUDES

- 1 x Basin set
- 1 x Anti vandal spanner
- 1 x Installation instructions
- 1 x Warranty card

[PLEASE CLICK HERE TO VIEW FULL WARRANTY](#)

While we aim to ensure the specifications shown are correct at time of printing, Phoenix Tapware reserves the right to make modifications without prior notice. Always use the physical product measurements for mark-ups and roughing-in as the line drawing shown may differ from the actual product over time. All measurements are shown in millimetres.

Ivy is a Registered Trademark of Phoenix Industries Pty Ltd

V230816

[www.phoenixtapware.com.au](http://www.phoenixtapware.com.au)  
03 9780 4200