



PHOENIX

SPECIFICATIONS

NOSTALGIA

SINK MIXER 160MM GOOSENECK

PRODUCT CODE: NS730 CHR
 FINISH: CHROME
 WELS: 4 STAR - 7.5 LT/MIN

INFORMATION:

TEMPERATURE RATING: MIN 1° - MAX 75°
 PRESSURE RATING: MIN 150 kPa - MAX 500 kPa



ALSO AVAILABLE IN:



ANTIQUÉ GOLD CHROME / WHITE

FOR MORE INFORMATION VISIT www.phoenixtapware.com.au

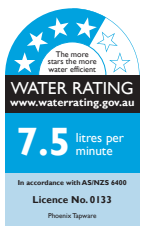
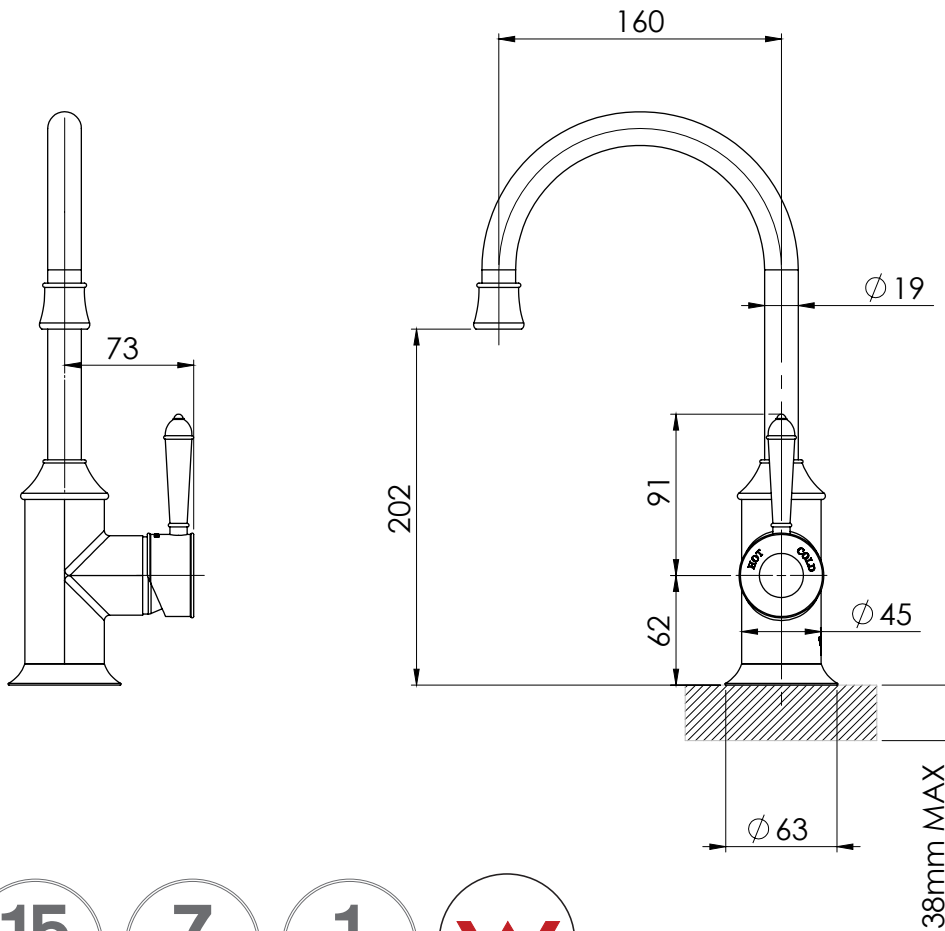

PLEASE [CLICK HERE](#) TO VIEW FULL WARRANTY

While we aim to ensure the specifications shown are correct at time of printing, Phoenix Tapware reserves the right to make modifications without prior notice. Always use the physical product measurements for mark-ups and roughing-in as the line drawing shown may differ from the actual product over time. All measurements are shown in millimetres.

Nostalgia is a Registered Trademark of Phoenix Industries Pty. Ltd.

V211116

www.phoenixtapware.com.au
03 9780 4200



PHOENIX

SPECIFICATIONS

NOSTALGIA

SINK MIXER 160MM GOOSENECK

PRODUCT CODE:

NS730 CHR

FINISH:

CHROME

WELS:

4 STAR - 7.5 LT/MIN



PARTS LIST

1. MIXER BODY
2. SPOUT BOSS
3. MIXER BODY COVER
4. LOWER SPOUT DISC
5. UPPER SPOUT DISC
6. SPOUT
7. O-RING 26X3.0MM
8. O-RING 7X2.5MM
9. 35MM CARTRIDGE
10. LOCKNUT
11. DOME
12. HANDLE BODY
13. PIN LEVER
14. GRUB SCREW M5X6
15. AERATOR
16. GASKET
17. RETAINER
18. M8 THREADED ROD
19. FIXING PLATE
20. FIXING RUBBER GASKET
21. M8 THREADED NUT
22. FLEXIBLE HOSE 450MM COLD
23. FLEXIBLE HOSE 450MM HOT
24. DRESS RING
25. O-RING 49X3.0MM

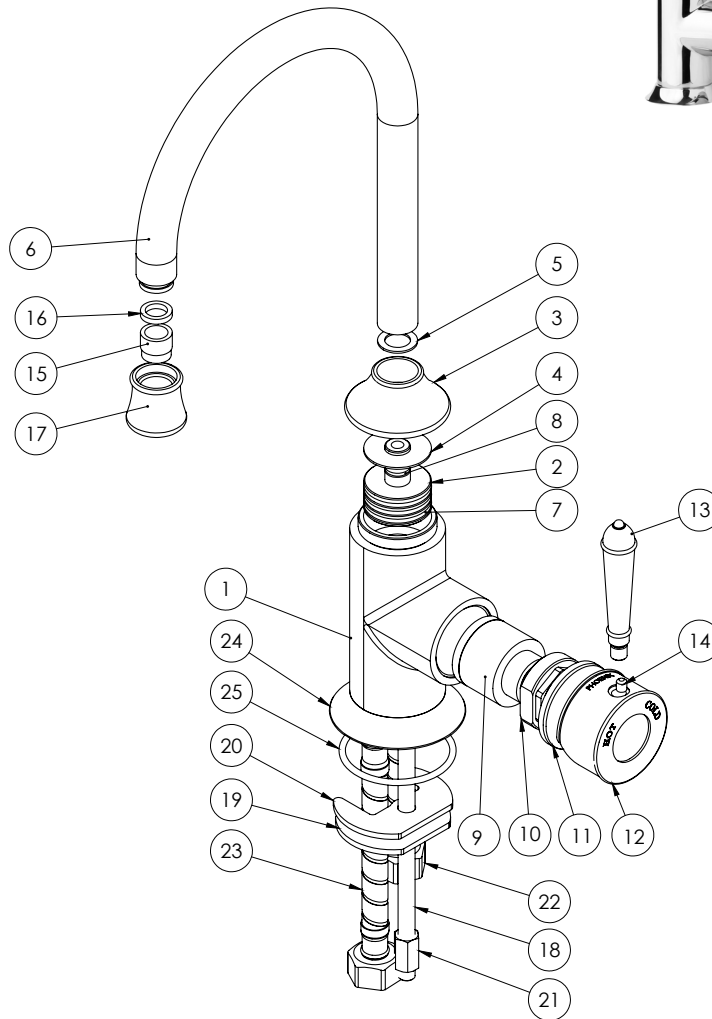

MAINTENANCE AND CARE:

- All surfaces should be cleaned with mild liquid detergent or soap and water.
- Do not use cream cleaners or citrus based cleaning products, as they are abrasive.
- Use of unsuitable cleaning agents may damage the surface. Any damage caused in this way will not be covered by warranty.

PACKAGING INCLUDES

- 1 x Sink mixer
- 1 x Dress ring
- 1 x Installation kit
- 1 x 450mm braided flexible cold hose
- 1 x 450mm braided flexible hot hose
- 1 x Installation instructions
- 1 x Warranty card

PLEASE [CLICK HERE](#) TO VIEW FULL WARRANTY

While we aim to ensure the specifications shown are correct at time of printing, Phoenix Tapware reserves the right to make modifications without prior notice. Always use the physical product measurements for mark-ups and roughing-in as the line drawing shown may differ from the actual product over time. All measurements are shown in millimetres.

Nostalgia is a Registered Trademark of Phoenix Industries Pty. Ltd.

V211116

www.phoenixtapware.com.au
03 9780 4200