



PHOENIX

SPECIFICATIONS

RADII

WALL BATH MIXER SET 280MM

PRODUCT CODE: RA764 CHR
 FINISH: CHROME
 WELS: N/A

INFORMATION:

TEMPERATURE RATING: MIN 1° - MAX 75°
 PRESSURE RATING: MIN 150 kPa - MAX 500 kPa



AVAILABLE IN:



CHROME

FOR MORE INFORMATION VISIT
www.phoenixtapware.com.au

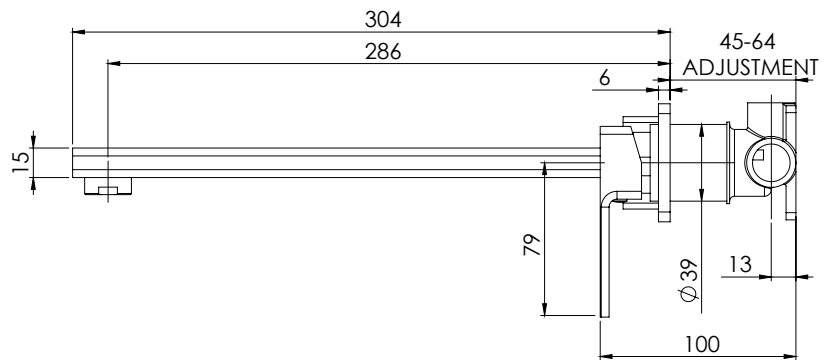
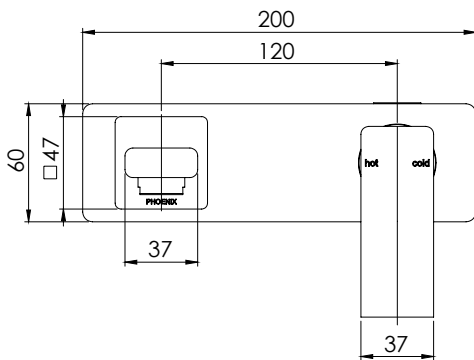

PLEASE [CLICK HERE](#) TO VIEW FULL WARRANTY

While we aim to ensure the specifications shown are correct at time of printing, Phoenix Tapware reserves the right to make modifications without prior notice. Always use the physical product measurements for mark-ups and roughing-in as the line drawing shown may differ from the actual product over time. All measurements are shown in millimetres.

Radii is a Registered Trademark of Phoenix Industries Pty. Ltd.

V050617

www.phoenixtapware.com.au
03 9780 4200



PHOENIX

SPECIFICATIONS

RADII

WALL BATH MIXER SET 280MM

PRODUCT CODE:

RA764 CHR

FINISH:

CHROME

WELS:

N/A



PARTS LIST

1. WALL BREACH 280MM
2. WALL MIXER BODY
3. 35MM CARTRIDGE
4. LOCKNUT
5. MIXER HANDLE
6. GRUB SCREW M4X6
7. O-RING
8. SCREW CAP
9. WALL BACKPLATE
10. SPOUT BLOCK
11. LOCATING PIN
12. WALL SPOUT 180MM
13. O-RING
14. RETAINING NOZZLE
15. AERATOR GASKET
16. GRUB SCREW M5X6
17. SPOUT ADAPTER
18. O-RING
19. GRUB SCREW M4X8
20. AERATOR
21. O-RING

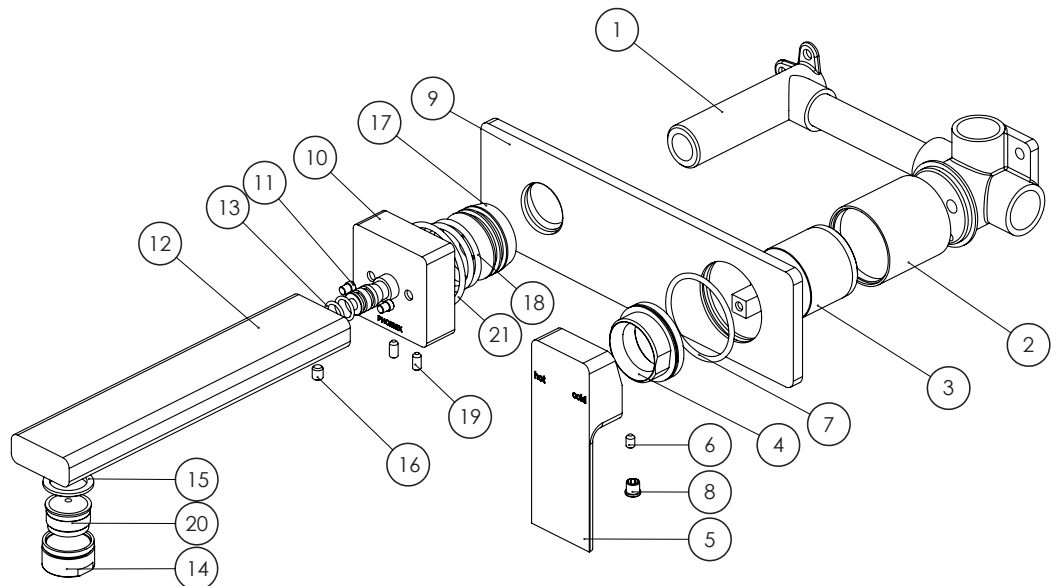

MAINTENANCE AND CARE:

- All surfaces should be cleaned with mild liquid detergent or soap and water.
- Do not use cream cleaners or citrus based cleaning products, as they are abrasive.
- Use of unsuitable cleaning agents may damage the surface. Any damage caused in this way will not be covered by warranty.

PACKAGING INCLUDES

- 1 x Wall bath set
- 1 x Installation kit
- 1 x Installation instructions
- 1 x Warranty card

PLEASE [CLICK HERE](#) TO VIEW FULL WARRANTY

While we aim to ensure the specifications shown are correct at time of printing, Phoenix Tapware reserves the right to make modifications without prior notice. Always use the physical product measurements for mark-ups and roughing-in as the line drawing shown may differ from the actual product over time. All measurements are shown in millimetres.

Radii is a Registered Trademark of Phoenix Industries Pty. Ltd.

V050617

www.phoenixtapware.com.au
03 9780 4200