



PHOENIX

SPECIFICATIONS

RUSH

WALL BASIN MIXER SET 230MM



PRODUCT CODE:	RU786 CHR
FINISH:	CHROME
WELS:	5 STAR - 5LT/MIN
INFORMATION:	
TEMPERATURE RATING:	MIN 1° - MAX 75°
PRESSURE RATING:	MIN 150 kPa - MAX 500 kPa

AVAILABLE IN:



CHROME MATTE BLACK

FOR MORE INFORMATION VISIT
www.phoenixtapware.com.au

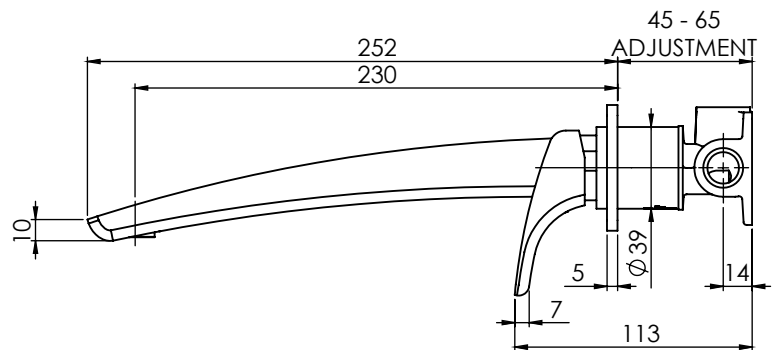
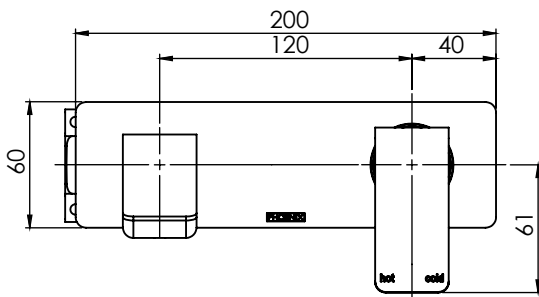

PLEASE [CLICK HERE](#) TO VIEW FULL WARRANTY

While we aim to ensure the specifications shown are correct at time of printing, Phoenix Tapware reserves the right to make modifications without prior notice. Always use the physical product measurements for mark-ups and roughing-in as the line drawing shown may differ from the actual product over time. All measurements are shown in millimetres.

www.phoenixtapware.com.au
03 9780 4200



PHOENIX

SPECIFICATIONS

RUSH

WALL BASIN MIXER SET 230MM

PRODUCT CODE:

RU786 CHR

FINISH:

CHROME

WELS:

5 STAR - 5LT/MIN



PARTS LIST

1. BREACH
2. 35MM CARTRIDGE
3. LOCKNUT DOME
4. MIXER SLEEVE
5. BACKPLATE
6. MIXER HANDLE
7. GRUB SCREW M4X5MM
8. SCREW CAP
9. O-RING 38X2.5MM
10. O-RING 33X2.0MM
11. AERATOR
12. G1/2" SPOUT ADAPTER
13. O-RING 13X2.6MM
14. O-RING 21X1.9MM
15. SPOUT 230MM

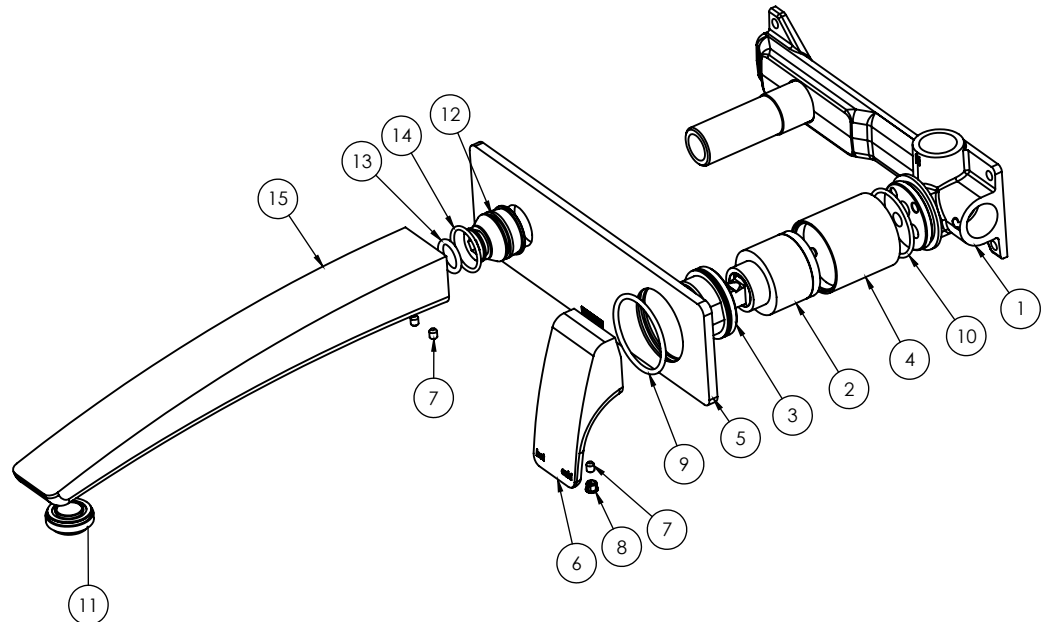

MAINTENANCE AND CARE:

- All surfaces should be cleaned with mild liquid detergent or soap and water.
- Do not use cream cleaners or citrus based cleaning products, as they are abrasive.
- Use of unsuitable cleaning agents may damage the surface. Any damage caused in this way will not be covered by warranty.

PACKAGING INCLUDES

- 1 x Wall basin mixer set 230mm
- 1 x Dress plate
- 1 x Mixer handle
- 1 x Spout
- 1 x Installation kit
- 1 x Installation instructions
- 1 x Warranty card

PLEASE [CLICK HERE](#) TO VIEW FULL WARRANTY

While we aim to ensure the specifications shown are correct at time of printing, Phoenix Tapware reserves the right to make modifications without prior notice. Always use the physical product measurements for mark-ups and roughing-in as the line drawing shown may differ from the actual product over time. All measurements are shown in millimetres.

www.phoenixtapware.com.au
03 9780 4200