



PHOENIX

SPECIFICATIONS

RUSH

RUSH WALL BATH SET 180MM

PRODUCT CODE: RU783 MB
 FINISH: MATTE BLACK
 WELS: N/A

INFORMATION:

TEMPERATURE RATING: MIN 1° - MAX 75°
 PRESSURE RATING: MIN 150 kPa - MAX 500 kPa



AVAILABLE IN:

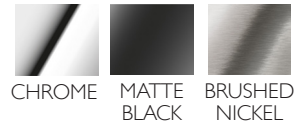

FOR MORE INFORMATION VISIT
www.phoenixtapware.com.au

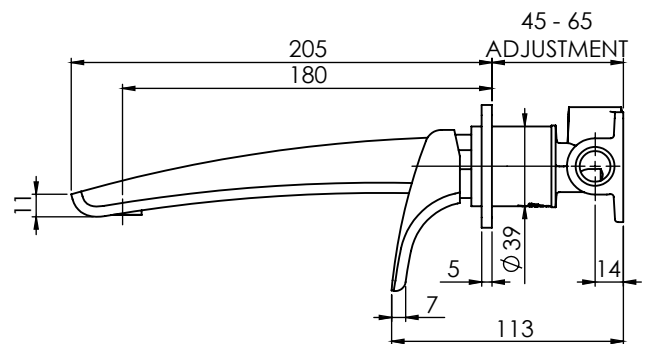
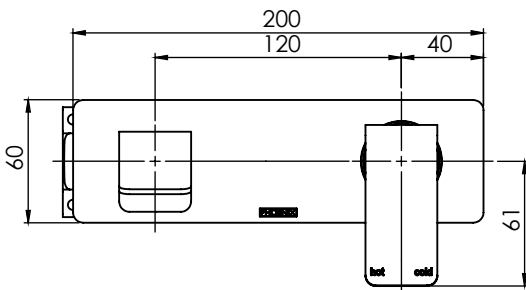

PLEASE [CLICK HERE TO VIEW FULL WARRANTY](#)

While we aim to ensure the specifications shown are correct at time of printing, Phoenix Tapware reserves the right to make modifications without prior notice. Always use the physical product measurements for mark-ups and roughing-in as the line drawing shown may differ from the actual product over time. All measurements are shown in millimetres.

www.phoenixtapware.com.au
 03 9780 4200



RUSH

RUSH WALL BATH SET 180MM

PRODUCT CODE:

RU783 MB

FINISH:

MATTE BLACK

WELS:

N/A



PARTS LIST

1. WALL BREACH
2. 35MM CARTRIDGE
3. LOCKNUT DOME
4. MIXER SLEEVE
5. BACKPLATE
6. MIXER HANDLE
7. GRUB SCREW M4X5MM
8. SCREW CAP
9. O-RING 38X2.5MM
10. O-RING 33X2.0MM
11. AERATOR MAX FLOW
12. SPOUT ADAPTER
13. O-RING 13X2.6MM
14. O-RING 21X1.9MM
15. SPOUT 180MM
16. SCREW

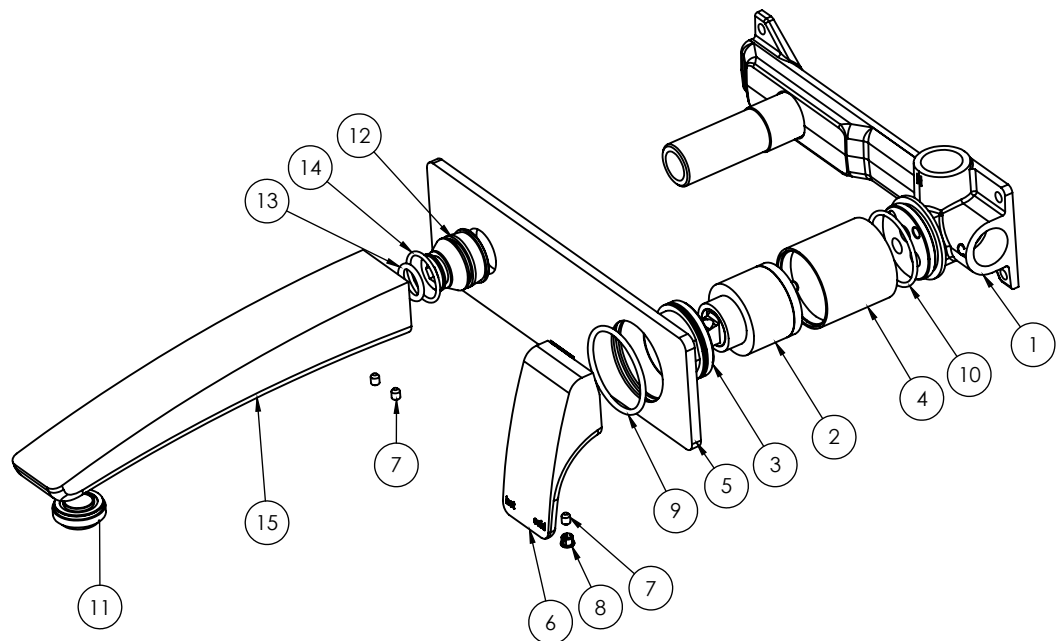

MAINTENANCE AND CARE:

- All surfaces should be cleaned with mild liquid detergent or soap and water.
- Do not use cream cleaners or citrus based cleaning products, as they are abrasive.
- Use of unsuitable cleaning agents may damage the surface. Any damage caused in this way will not be covered by warranty.

PACKAGING INCLUDES

- 1 x Wall bath set 180mm
- 1 x Installation kit
- 1 x Installation instructions
- 1 x Warranty card

PLEASE [CLICK HERE](#) TO VIEW FULL WARRANTY

While we aim to ensure the specifications shown are correct at time of printing, Phoenix Tapware reserves the right to make modifications without prior notice. Always use the physical product measurements for mark-ups and roughing-in as the line drawing shown may differ from the actual product over time. All measurements are shown in millimetres.

www.phoenixtapware.com.au
03 9780 4200