



PHOENIX

SPECIFICATIONS

VIVID

BASIN MIXER EXTENDED PIN

PRODUCT CODE:	VE770
FINISH:	CHROME
WELS:	5 STAR - 6.0 LT/MIN

INFORMATION:

TEMPERATURE RATING:	MIN 1° - MAX 75°
PRESSURE RATING:	MIN 150 kPa - MAX 500 kPa



AVAILABLE IN:



CHROME

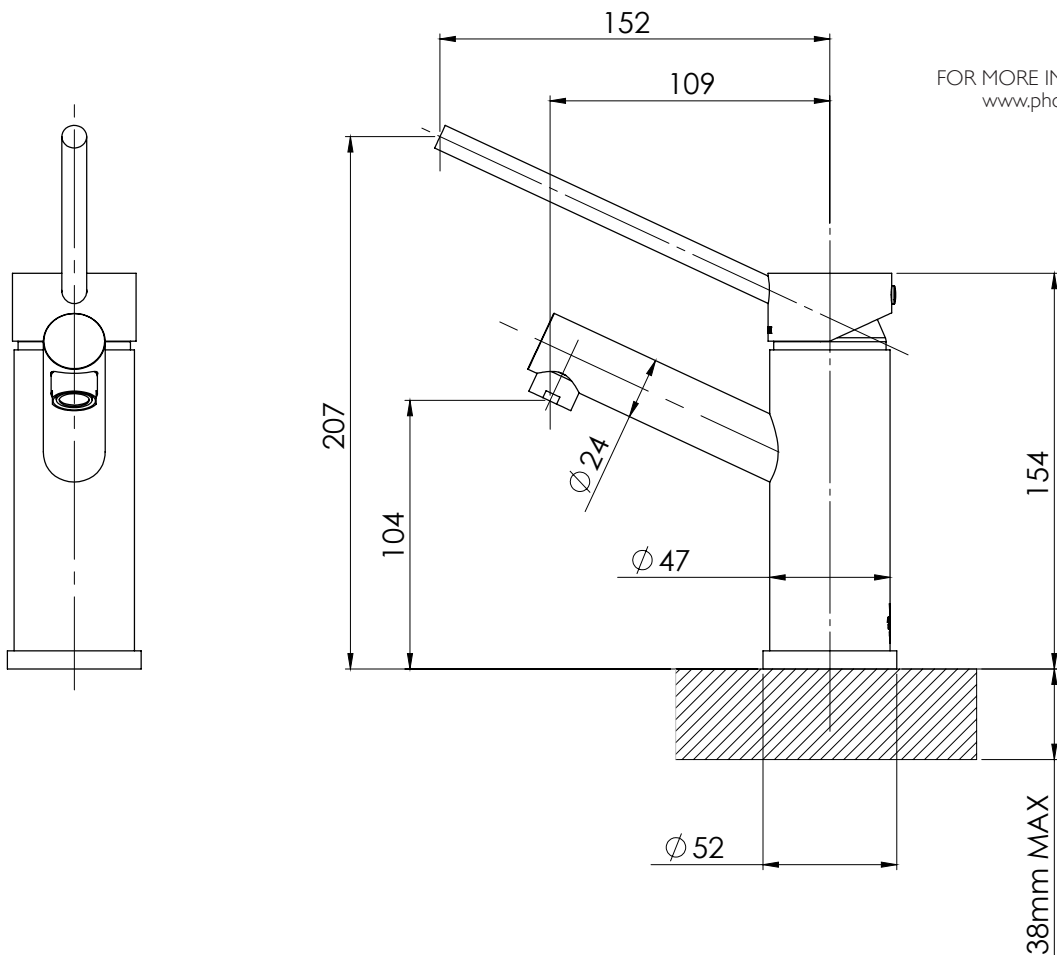

FOR MORE INFORMATION VISIT www.phoenixtapware.com.au



PLEASE [CLICK HERE](#) TO VIEW FULL WARRANTY

While we aim to ensure the specifications shown are correct at time of printing, Phoenix Tapware reserves the right to make modifications without prior notice. Always use the physical product measurements for mark-ups and roughing-in as the line drawing shown may differ from the actual product over time. All measurements are shown in millimetres.

www.phoenixtapware.com.au
03 9780 4200



PHOENIX

SPECIFICATIONS

VIVID

BASIN MIXER EXTENDED PIN

PRODUCT CODE:

VE770

FINISH:

CHROME

WELS:

5 STAR - 6.0 LT/MIN

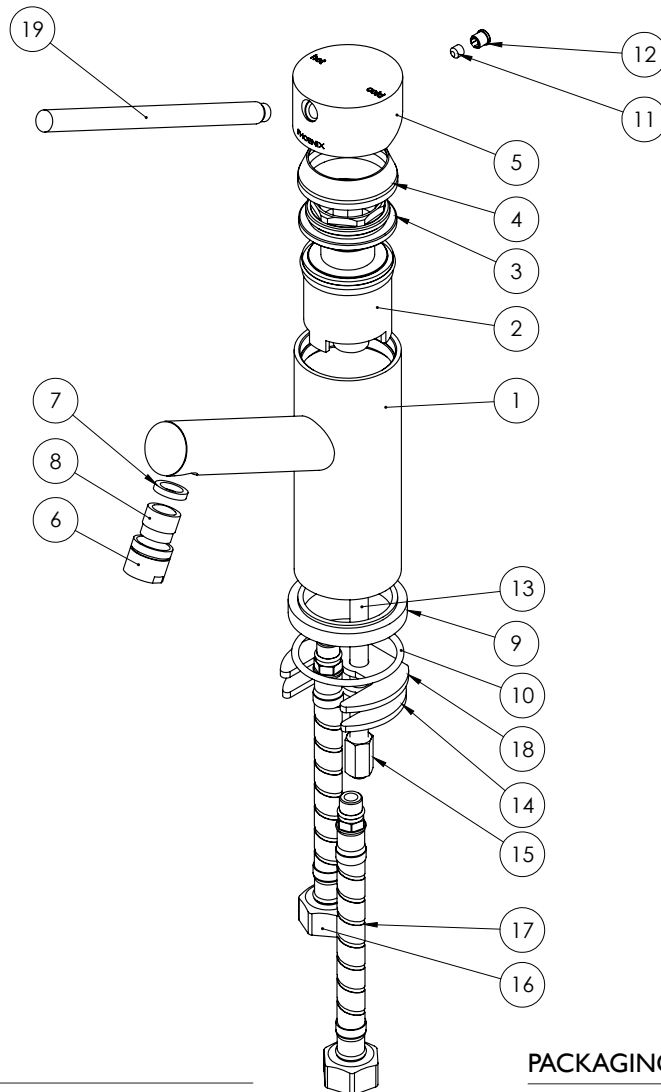

PARTS LIST

1. MIXER BODY
2. 35MM CARTRIDGE
3. LOCKNUT
4. DOME
5. MIXER HANDLE
6. AERATOR RETAINER
7. GASKET
8. AERATOR
9. DRESS RING
10. O-RING 43X3.0MM
11. GRUB SCREW
12. SCREW CAP
13. M8 THREADED ROD
14. FIXING PLATE
15. M8 THREADED NUT
16. FLEXIBLE HOSE 450MM HOT
17. FLEXIBLE HOSE 450MM COLD
18. RUBBER GASKET
19. LEVER PIN

MAINTENANCE AND CARE:

- All surfaces should be cleaned with mild liquid detergent or soap and water.
- Do not use cream cleaners or citrus based cleaning products, as they are abrasive.
- Use of unsuitable cleaning agents may damage the surface. Any damage caused in this way will not be covered by warranty.

PACKAGING INCLUDES

- 1 x Basin mixer
- 1 x 450mm braided flexible cold hose
- 1 x 450mm braided flexible hot hose
- 1 x Installation kit
- 1 x Installation instructions
- 1 x Warranty card

PLEASE [CLICK HERE](#) TO VIEW FULL WARRANTY

While we aim to ensure the specifications shown are correct at time of printing, Phoenix Tapware reserves the right to make modifications without prior notice. Always use the physical product measurements for mark-ups and roughing-in as the line drawing shown may differ from the actual product over time. All measurements are shown in millimetres.

www.phoenixtapware.com.au
03 9780 4200