



PHOENIX

SPECIFICATIONS

VIVID SLIMLINE

SINK MIXER 160MM GOOSENECK

PRODUCT CODE: VS735 BN
 FINISH: BRUSHED NICKEL
 WELS: 4 STAR - 7.5 LT/MIN

INFORMATION:

MATERIAL: BRASS
 TEMPERATURE RATING: MIN 1° - MAX 75°
 PRESSURE RATING: MIN 150 kPa - MAX 500 kPa

CONSUMER UNIT:

SIZE: L 320MM x W 275MM x H 75MM
 GROSS WEIGHT: 1.65 KG
 BARCODE EAN-13: 9 320594 008 529



ALSO AVAILABLE IN:

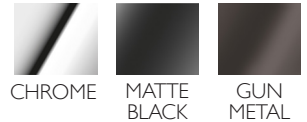

FOR MORE INFORMATION VISIT www.phoenixtapware.com.au

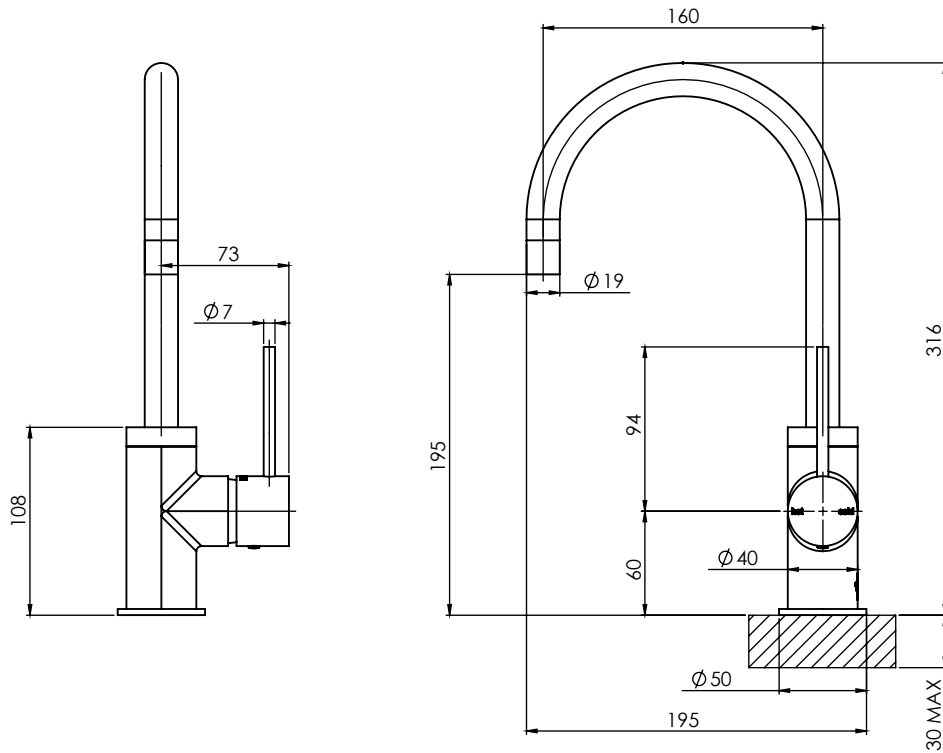

PLEASE [CLICK HERE TO VIEW FULL WARRANTY](#)

While we aim to ensure the specifications shown are correct at time of printing, Phoenix Tapware reserves the right to make modifications without prior notice. Always use the physical product measurements for mark-ups and roughing-in as the line drawing shown may differ from the actual product over time. All measurements are shown in millimetres.

www.phoenixtapware.com.au
03 9780 4200



PHOENIX

SPECIFICATIONS

VIVID SLIMLINE

SINK MIXER 160MM GOOSENECK

PRODUCT CODE:

VS735 BN

FINISH:

BRUSHED NICKEL

WELS:

4 STAR - 7.5 LT/MIN



PARTS LIST

1. MIXER BODY
2. SPOUT BOSS
3. MIXER BODY COVER
4. LOWER SPOUT DISC
5. UPPER SPOUT DISC
6. GOOSENECK SPOUT
7. O-RING 26X3.0MM
8. O-RING 7X2.5MM
9. 35MM CARTRIDGE
10. MIXER LOCKNUT
11. MIXER DOME
12. MIXER HANDLE
13. LEVER HANDLE
14. GRUB SCREW M5X6MM
15. AERATOR
16. AERATOR GASKET
17. AERATOR RETAINER
18. M8 THREADED ROD
19. FIXING PLATE
20. RUBBER GASKET
21. M8 NUT
22. FLEXIBLE HOSE 450MM COLD
23. FLEXIBLE HOSE 450MM HOT
24. DRESS PLATE
25. SCREW CAP
26. O-RING 27X2MM
27. O-RING 39X3MM

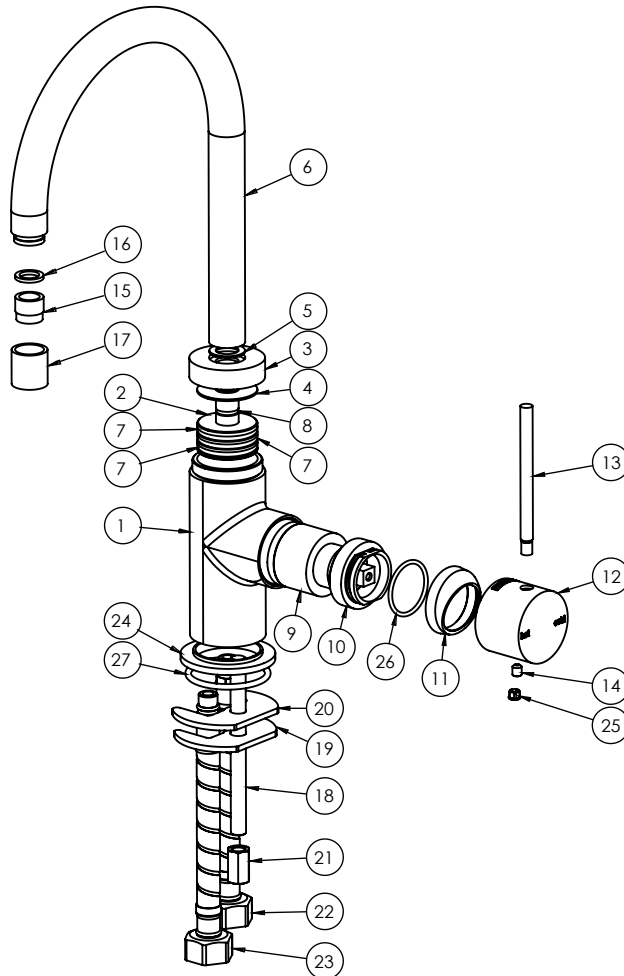

MAINTENANCE AND CARE:

- All surfaces should be cleaned with mild liquid detergent or soap and water.
- Do not use cream cleaners or citrus based cleaning products, as they are abrasive.
- Use of unsuitable cleaning agents may damage the surface. Any damage caused in this way will not be covered by warranty.

PACKAGING INCLUDES

- 1 x Sink mixer 160mm gooseneck
- 1 x Installation kit
- 1 x 450mm braided flexible cold hose
- 1 x 450mm braided flexible hot hose
- 1 x AF11 spanner
- 1 x Installation instructions
- 1 x Warranty card

PLEASE [CLICK HERE](#) TO VIEW FULL WARRANTY

While we aim to ensure the specifications shown are correct at time of printing, Phoenix Tapware reserves the right to make modifications without prior notice. Always use the physical product measurements for mark-ups and roughing-in as the line drawing shown may differ from the actual product over time. All measurements are shown in millimetres.

www.phoenixtapware.com.au
03 9780 4200