

apaiser



## COLLABORATIONS - WOHAbeing

### Sampan double basin

1500mm

The Sampan Double Basin is a remarkable, semi recessed vanity design. Drawing upon the angular and low profile form of the Sampan boat, combined with generous proportions and fine detail, the basin is reminiscent of a marine sculpture for the bathroom.

#### SPECIFICATIONS

1500mm x 420mm x 255mm

Approx weight: 90kg (198lb)

Chrome or stone waste included.



Product code **6294**

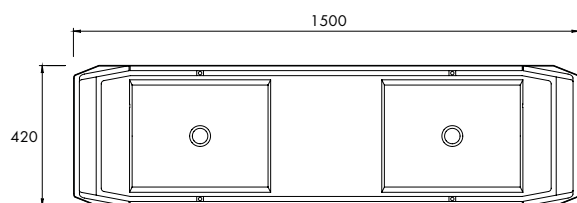

NOTE:  
THE SAMPAN DOUBLE BASIN IS DESIGNED TO BE RECESSED INTO THE COUNTERTOP BY 75MM.

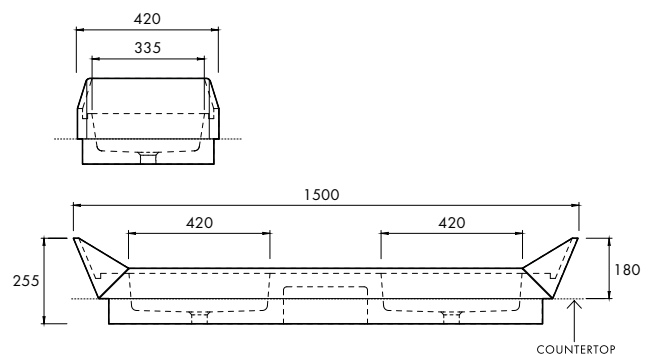

## apaiserMARBLE

apaiserMARBLE® is a luxurious, performative, non-porous marble material, derived from reclaimed marble, enriched with the purity of Australian minerals. Offering enhanced performance, achieved through the integration of the most advanced materials, apaiserMARBLE is shaped and perfected by our master craftsmen.

We at apaiser are committed to manufacturing bathware, which is respectful of the environment. In all phases of our process, we strive to produce a product with consistently low environmental impact.

## apaiserCARE

A dedicated support platform comprising apaiser's in-house design and engineering professionals, provides superior service quality and peace of mind to all our project customers and retail installations. apaiserCARE® oversees design to delivery, installation and training.